

## 100G QSFP28 SR4 100M OPTICAL TRANSCEIVER

### KAB-QSFP28-SR4

#### Features

- ❖ Up to 103.1Gbps Data rate per channel
- ❖ Up to 100m transmission on OM4 MMF
- ❖ 4 channels 850nm VCSEL array
- ❖ 4 channels PIN photo detector array
- ❖ Hot-pluggable QSFP28 form factor
- ❖ Single MPO connector receptacle
- ❖ Internal CDR circuits on both receiver and Transmitter channels
- ❖ Support CDR bypass
- ❖ Built-in digital diagnostic functions
- ❖ Single +3.3V power supply
- ❖ Low power consumption < 2.5 W
- ❖ Operating case temperature : 0~+70°C
- ❖ 4 channel full duplex transceiver modules



#### Applications

- ❖ 100GBASE-SR4 100G Ethernet
- ❖ Infiniband EDR, FDR, QDR
- ❖ Other optical links

#### Standards

- ❖ Compliant with SFF-8665 Specification
- ❖ Compliant with IEEE 802.3bm 100GBASE-SR4
- ❖ Compliant with Telcordia GR-468-CORE
- ❖ RoHS Compliant

#### Ordering information

Part Number	Product Description
KAB-QSFP28-SR4	850nm array VCSEL, MPO, 103.125Gbps, OM4 MMF 100m, 0°C ~ +70°C

## Description

The transceiver is a four-channel, pluggable, parallel, fiber-optic QSFP28 SR4 transceiver module for 100GBASE-SR4 and 100G Ethernet, InfiniBand EDR, FDR, Q DR applications. This high-performance module is designed for data communication and interconnect applications. It integrates four data lanes in each direction with 100Gb/s bandwidth. Each lane can operate at 25.78125Gb/s up to 70 m transmission distance using OM3 fiber or 100 m transmission distance using OM4 fiber. These modules are designed to operate over multi-mode fiber systems using a nominal wavelength of 850nm. The electrical interface uses a 38-pin contact edge type connector. The optical interface uses a 12 fiber MTP(MPO) connector. This module incorporates Technologies proven circuit and Optical technology to provide reliable long life, high performance, and consistent service.

## Block Diagram

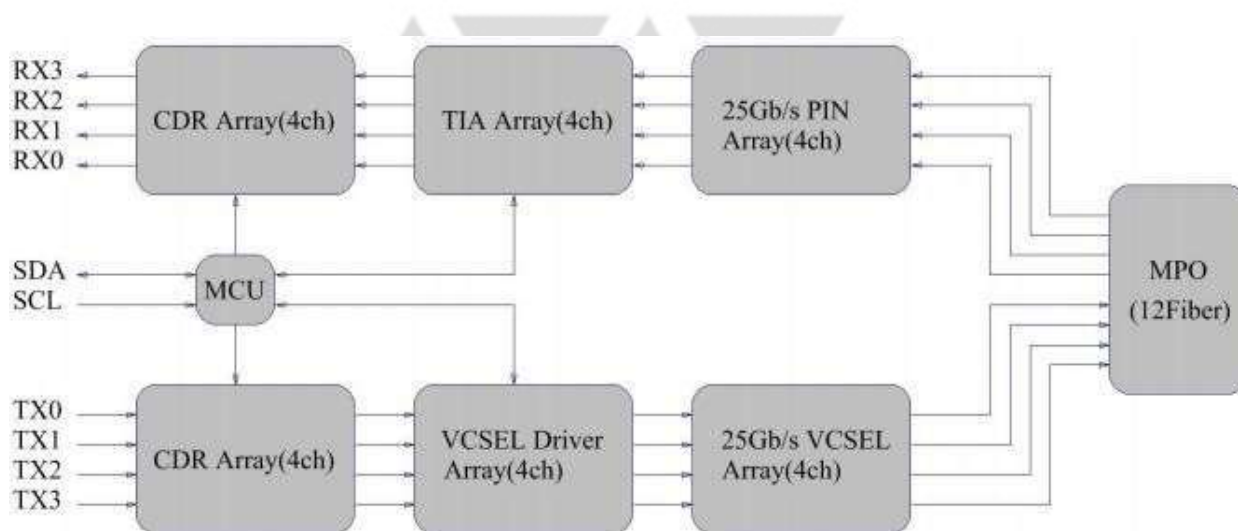

## Absolute Maximum Ratings

Parameter	Symbol	Min	Typ	Max	Unit	Notes
Maximum Supply Voltage	VCC	-0.5	-	+4.0	V	
Storage Temperature	Ts	-40	-	+85	°C	
Case Operating Temperature	TA	-5	-	+75	°C	
Relative Humidity	RH	5	-	95	%	1
Receiver Damage Threshold, each lane	PRdmg	3.4	-	-	dBm	

### Notes:

1. Non-condensing.

*Exceeding the limits below may damage the transceiver module permanently.*

### Recommended Operating Conditions

Parameter	Symbol	Min	Typ	Max	Unit	Notes
Data Rate,each lane	BR	-	25.78125	-	Gbps	
Data Rate Variation, each lane		-100	-	+100	ppm	
Power Supply Voltage	Vcc	3.13	3.3	3.47	V	
Power Supply Current	Icc	-	-	750	mA	
Power Dissipation	Pd	-	-	2.5	W	
Case Operating Temperature	Ta	0	-	+70	°C	
Relative Humidity	RH	5	-	85	%	1
Transmission Distance	Td	-	-	100	m	2

#### Notes:

1. Non-condensing.
2. Measured with ITU-T G.651 OM4 MMF

### Electrical Optical Characteristics (TOP = 0 to +70 °C, VCC = 3.13 to 3.47 V)

Parameter	Symbol	Min	Typ	Max	Unit	Notes
<b>Transmitter</b>						
Differential Data Input Amplitude	V <sub>in,p-p</sub>	180	-	900	mVpp	
Input Differential Impedance	Z <sub>in</sub>	90	100	110	Ω	
Transmitter Fault Output-High	V <sub>oh</sub>	2.4	-	V <sub>cc</sub>	V	
Transmitter Fault Output-Low	V <sub>ol</sub>	-0.3	-	0.4	V	
Transmitter Disable Voltage- High	V <sub>ih</sub>	2.0	-	V <sub>cc</sub>	V	
Transmitter Disable Voltage- low	V <sub>il</sub>	0	-	0.8	V	
<b>Receiver</b>						
Differential output voltage swing	V <sub>out, p-p</sub>	300	-	900	mVpp	
Output Differential Impedance	Z <sub>out</sub>	90	100	110	Ω	
LOS Output Voltage-High	V <sub>losh</sub>	2.0	-	V <sub>cc</sub>	V	
LOS Output Voltage-Low	V <sub>losl</sub>	-	-	0.8	V	

### Optical Characteristics (TOP = 0 to +70 °C VCC = 3.13 to 3.47 V)

Parameter	Symbol	Min	Typ	Max	Unit	Notes
<b>Transmitter</b>						
Optical Center Wavelength	λ <sub>C</sub>	840	850	860	nm	
RMS Spectral Width	σ	-	-	0.6	nm	
Data Rate, each lane	BR	-	25.78125	-	Gbps	
Data Rate Variation, each lane		-100	-	+100	ppm	
Average Launch Power,each lane	P <sub>o</sub>	-8.4	-	+2.4	dBm	1
Optical Modulation Amplitude, each lane	P <sub>oma</sub>	-6.4	-	3.0	dBm	
Optical Extinction Ratio	ER	2.0	-	-	dB	
Transmitter and dispersion eye closure, each lane	TDEC	-	-	4.3	dBm	
Launch Power(OMA) minus TDEC, each lane	P-TDEC	-7.3	-	-	dBm	

Parameter	Symbol	Min	Typ	Max	Unit	Notes
Optical Return Loss Tolerance	ORL	-	-	12	dB	
Average Launch power of Tx OFF, each lane	POFF	-	-	-30	dBm	
Transmitter Eye Mask coordinates: X1, X2, X3, Y1, Y2, Y3	SPECIFICATION VALUES {0.3,0.38,0.45,0.35,0.41,0.5}					2
Receiver						
Center Wavelength Range	$\lambda C$	840	850	860	nm	
Data Rate, each lane	BR	-	25.78125	-	Gbps	
Data Rate Variation, each lane		-100	-	+100	ppm	
Receiver Power(OMA), each lane	POMA	-	-	3.0	dBm	
Average Receive Power, each lane	RPO	-10.3	-	+2.4	dBm	1
Receiver Sensitivity(OMA), each lane	RSEN	-	-	-10.3	dBm	3
Stressed Receiver Sensitivity (OMA), each lane	RSRS	-	-	-5.2	dBm	
LOS Assert	LOSA	-30	-	-	dBm	
LOS De-Assert	LOSD	-	-	-12	dBm	
LOS Hysteresis	LOSH	0.5	-	5.0	dB	
Receiver Reflectance	RR	-	-	-12	dB	

**Notes:**

1. Average launch/receive power, each lane (min) is informative and not the principal indicator of signal strength. A transmitter with launch/receive power below this value cannot be compliant; however, a value above this does not ensure compliance.
2. Hit Ratio  $5 \times 10^{-5}$  hits/sample
3. Measured with worst ER=2.0dB, RPBS 2^31-1 test pattern @25.78125Gbps BER=<5E-5

**Pin Assignment**

Pin	Symbol	Name/Description	Notes
1	GND	Ground	1
2	Tx2n	Transmitter Inverted Data Input	
3	Tx2p	Transmitter Non-Inverted Data Input	
4	GND	Ground	1
5	Tx4n	Transmitter Inverted Data Input	
6	Tx4p	Transmitter Non-Inverted Data Input	
7	GND	Ground	1
8	ModSelL	Module Select	2
9	ResetL	Module Reset	2
10	Vcc Rx	+3.3 V Power supply receiver	
11	SCL	2-wire serial interface clock	2
12	SDA	2-wire serial interface data	2
13	GND	Ground	1
14	Rx3p	Receiver Non-Inverted Data Output	
15	Rx3n	Receiver Inverted Data Output	

Pin	Symbol	Name/Description	Notes
16	GND	Ground	1
17	Rx1p	Receiver Non-Inverted Data Output	
18	Rx1n	Receiver Inverted Data Output	
19	GND	Ground	1
20	GND	Ground	
21	Rx2n	Receiver Inverted Data Output	
22	Rx2p	Receiver Non-Inverted Data Output	
23	GND	Ground	1
24	Rx4n	Receiver Inverted Data Output	
25	Rx4p	Receiver Non-Inverted Data Output	
26	GND	Ground	1
27	ModPrsL	Module Present	
28	IntL	Interrupt	2
29	Vcc Tx	+3.3 V Power supply transmitter	
30	Vcc1	+3.3 V Power Supply	
31	LPMODE	Low Power Mode	2
32	GND	Ground	1
33	Tx3p	Transmitter Non-Inverted Data Input	
34	Tx3n	Transmitter Inverted Data Input	
35	GND	Ground	1
36	Tx1p	Transmitter Non-Inverted Data Input	
37	Tx1n	Transmitter Inverted Data Input	
38	GND	Ground	1

**Notes:**

1. Circuit ground is internally isolated from chassis ground.
2. Open collector; should be pulled up with a 4.7k  $\Omega$  to 10k  $\Omega$  resistor on host board to a voltage between 3.15V and 3.6V

**Host PCB QSFP28 pad assignment top view and Names**

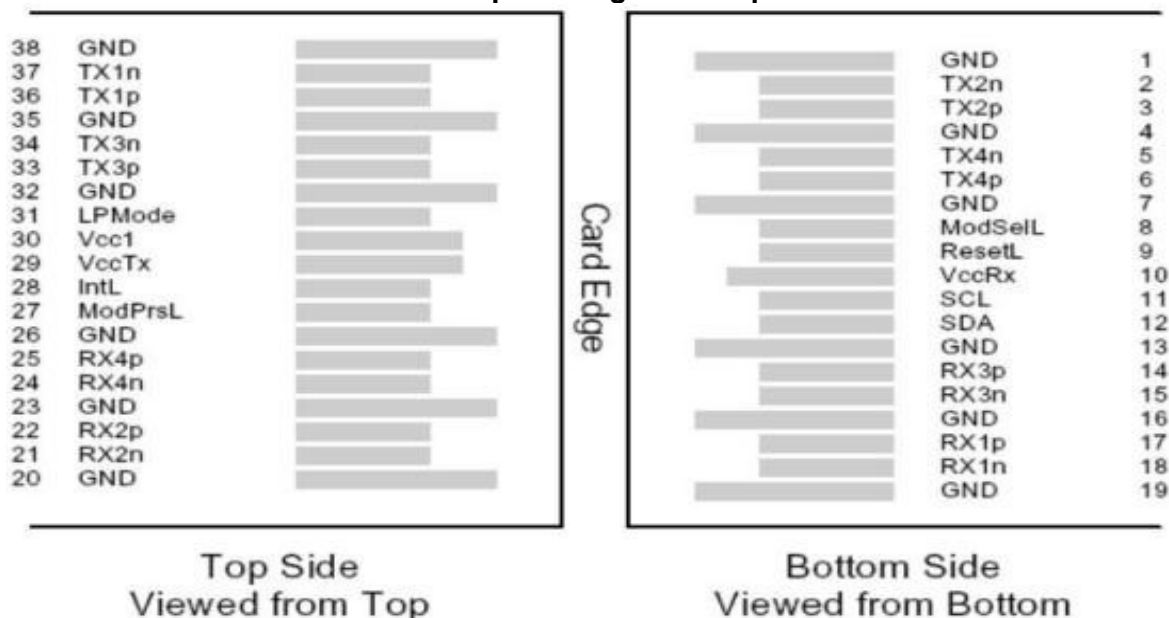

## Optical Interface Lanes and Assignment

The optical interface port is a male MPO connector, the keying feature of the MPO receptacle is on the top, then fibers are numbered left to right as 12 through 1 looking into the receptacle. The four fiber positions on the left (fibers 12, 11, 10, 9) are used for the optical transmit signals (Channel 1 through 4). The fiber positions on the right (fibers 4, 3, 2, 1) are used for the optical receive signals (Channel 4 through 1). The central four fibers (5, 6, 7, 8) may be physically present.

### QSFP28 Optical Receptacle and Channel Orientation

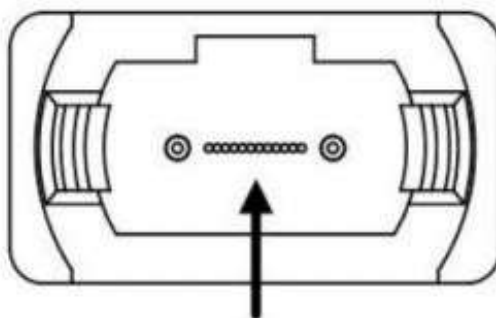

Fiber Number:	12	11	10	9	x	x	x	x	4	3	2	1
Transmit Channels:	1	2	3	4								
Receive Channels:									4	3	2	1

## Digital Diagnostic Monitoring Interface

Digital diagnostics monitoring function is available on all QSFP28 module. A 2-wire serial interface provides user to contact with module. The structure of the memory is shown in Figure below. The memory space is arranged into a lower, single page, address space of 128 bytes and multiple upper address space pages. This structure

permits timely access to addresses in the lower page, such as Interrupt Flags and Monitors. Less time critical time entries, such as serial ID information and threshold settings, are available with the Page Select function. The interface address used is A0xh and is mainly used for time critical data like interrupt handling in order to enable a one-time-read for all data related to an interrupt situation. After an interrupt, IntL, has been asserted, the host can read out the flag field to determine the affected channel and type of flag.

### QSFP28 Memory Map (Specific Data Field Descriptions)

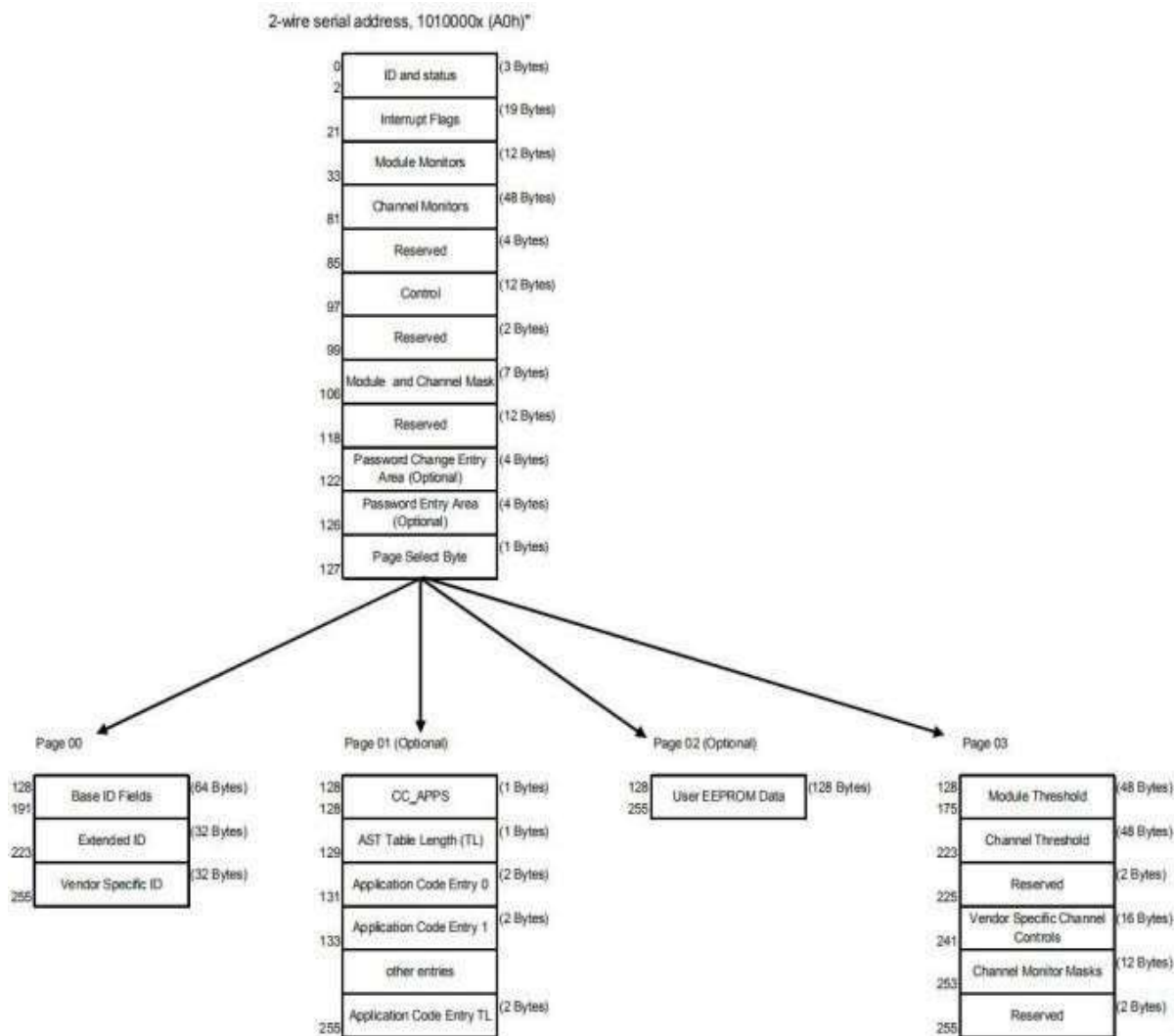

### Digital Diagnostic Monitor Characteristics

Parameter	Calibration	Range	Accuracy	Unit
Transceiver Internal Temperature	Internal	0 to +70°C	±3.0	°C
VCC Internal Supply Voltage	Internal	3.0 to 3.6V	±3.0	%
Laser Bias Current, each lane	Internal	0 to 20mA	±10	%
Tx Output Power, each lane	Internal	-8.4 to +2.4dBm	±3.0	dBm
Rx Input Power, each lane	Internal	-12.0 to 0dBm	±3.0	dBm

### Timing and Electrical

Parameter	Symbol	Min	Typ	Max	Unit
Initialization Time	t_init	-	-	2000	ms
Reset Init Assert Time	t_reset_init	-	-	2	us

Parameter	Symbol	Min	Typ	Max	Unit
Serial Bus Hardware Ready Time	t_serial	-	-	2000	ms
Monitor Data Ready Time	t_data	-	-	2000	ms
Reset Assert Time	t_reset	-	-	2000	ms
LPMode Assert Time	ton_LPMode	-	-	100	us
IntL Assert Time	ton_IntL	-	-	200	ms
IntL Deassert Time	toff_IntL	-	-	500	us
Rx LOS Assert Time	ton_los	-	-	100	ms
Tx Fault Assert Time	ton_Txfault	-	-	200	ms
Flag Assert Time	ton_flag	-	-	200	ms
Mask Assert Time	ton_mask	-	-	100	ms
Mask Deassert Time	toff_mask	-	-	100	ms
ModSelL Assert Time	ton_ModSelL	-	-	100	us
ModSelL Deassert Time	toff_ModSelL	-	-	100	us
Power_over-ride or Power-set Assert Time	ton_Pdown	-	-	100	ms
Power_over-ride or Power-set Deassert Time	toff_Pdown	-	-	300	ms

### Recommended Host Board Power Supply Circuit

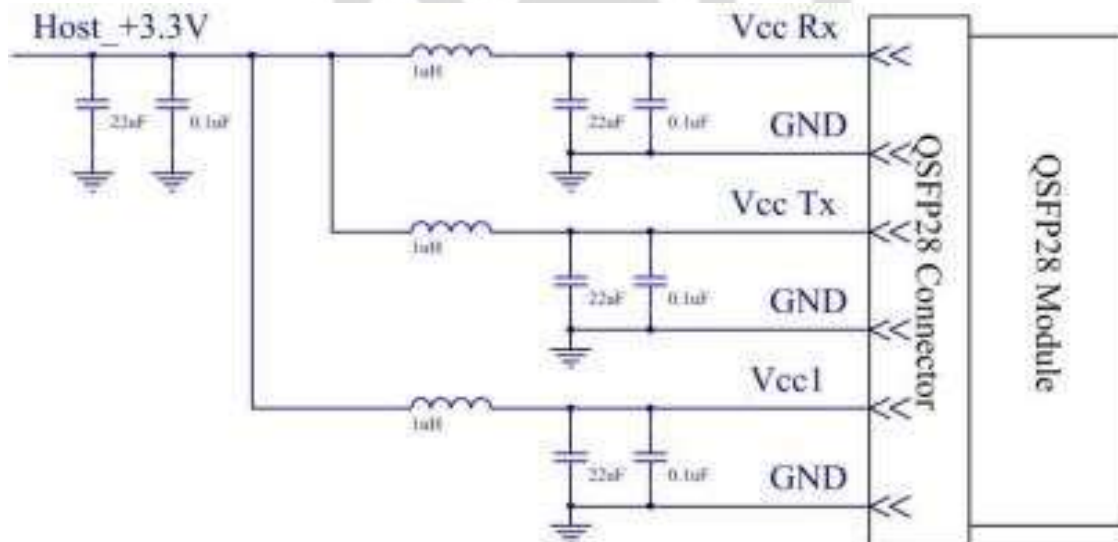

### Recommended Interface Circuit

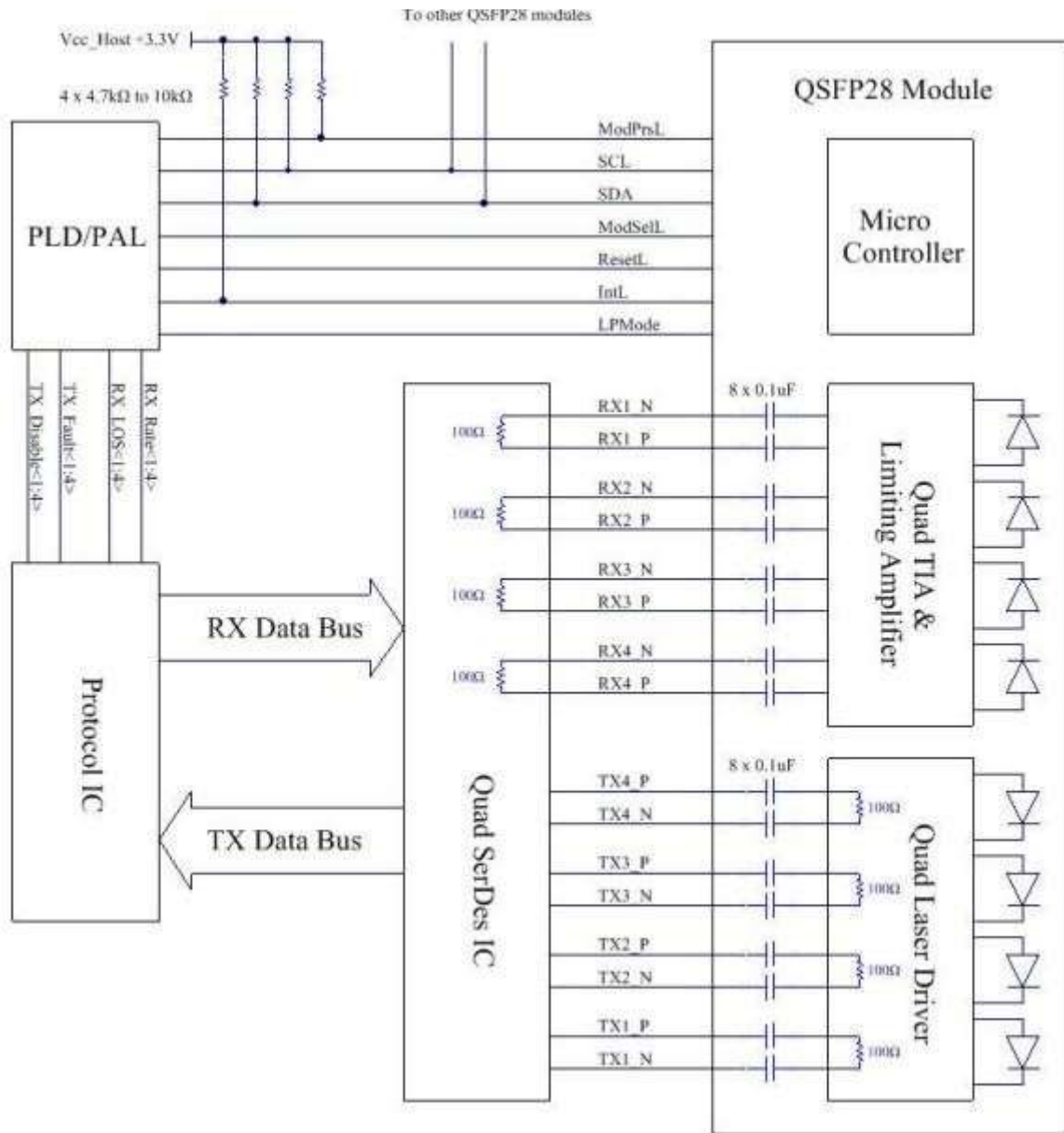

## Mechanical Dimensions

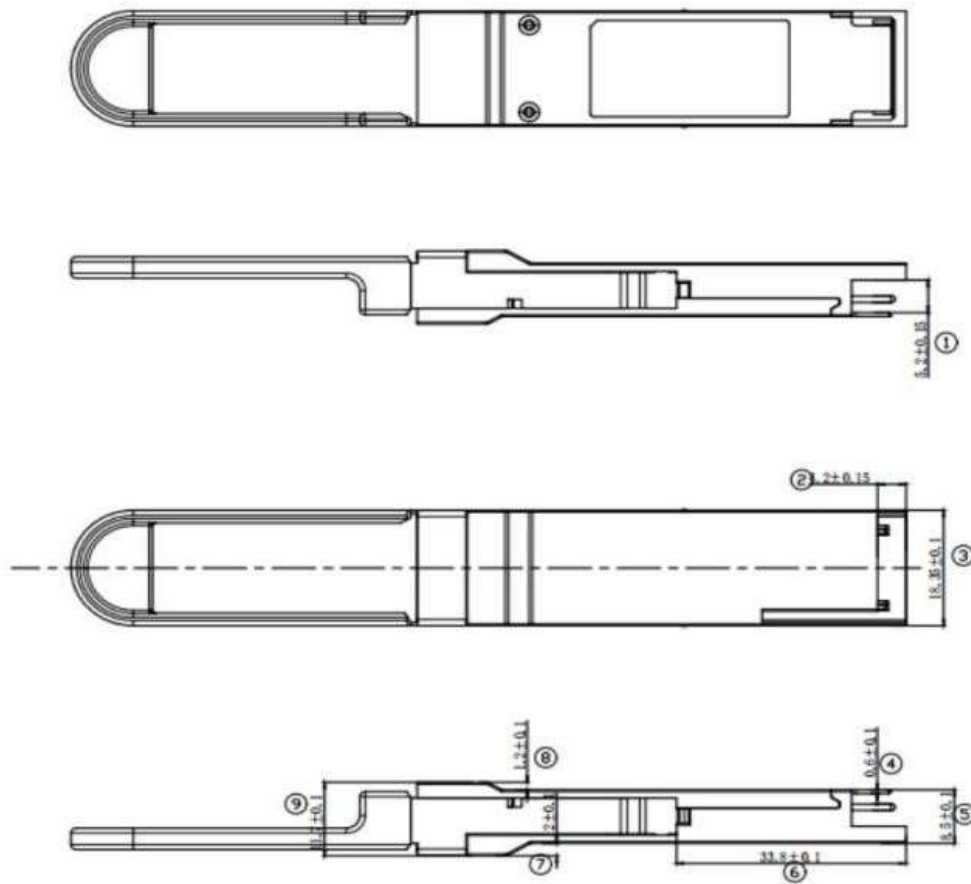

## Regulatory Compliance

Feature	Standard	Performance
Electrostatic Discharge (ESD) to the Electrical Pins	MIL-STD-883 Method 3015.7	Class 1(>1000V for SFI pins, >2000V for other pins.)
Electrostatic Discharge (ESD) to the Duplex LC Receptacle	IEC 61000-4-2 GR-1089-CORE	Compatible with standards
Electromagnetic Interference (EMI)	FCC Part 15 Class B	Compatible with standards
Immunity	IEC 61000-4-3	Compatible with standards
Laser Eye Safety	FDA 21CFR 1040.10 and 1040.11	Compatible with Class I laser product
RoHS	2.0(2015/863/EU)-amending	Compatible with standards

## Warnings

**Handling Precautions:** This device is susceptible to damage as a result of electrostatic discharge (ESD). A static free environment is highly recommended. Follow guidelines according to proper ESD procedures.

**Laser Safety:** Radiation emitted by laser devices can be dangerous to human eyes. Avoid eye exposure to direct or indirect radiation.